

Draughtproofing Guide

We would like to gratefully thank and acknowledge

Hyde Farm CAN and Sue Sheehan

for creating the original Draught Busting Workshops,
product research and allowing us to adapt and use their
original version of this manual

Table of Contents

General Advice	2-3
Product information and tools	4
Sash Windows SBS strip	5
Sash meeting rails and French doors FS strip	6
Outside doors 21B strip	7
Installation instructions	8
Letter box brush Door brushes	9
Magnaglaze added glazing, Double glazing film	10
Draughtex Floorboard gap filler	11
Radiator Panels	12
Measuring your doors and windows	13-14

General Advice

A draft is usually a sign of inadequate insulation which allows cold air to enter a house while warm air exits.

When drafts are uncomfortable we tend to leave the heating on longer or turn up the thermostat, increasing heating bills and causing higher carbon emissions (from the fuel burnt to create the warmth in the first place.)

Comprehensive draught proofing can reduce bills by up to 20%



te
house

on
lights

: to

e bills

to have some ventilation in order to keep
lations currently recommend a target of 5 air
much higher levels than this due to the large
gaps between floor boards, open fireplaces

Too Much Ventilation?

With a well-insulated home, it is important to have some ventilation in order to keep rooms from becoming stuffy.

Most older houses have much higher levels of recommended air changes due to the large number of small openings, structural cracks, gaps between floor boards, open fireplaces etc. and so in practice it is quite difficult to over-apply draught proofing in these older houses.

The exceptions are bathrooms and kitchens, which produce high amounts of condensation and must be ventilated correctly to prevent mould and similar problems.

Remember also that adequate ventilation is essential in rooms with solid fuel fires, gas fires or a boiler with an open flue.

To Find draughts in your home

Choose a cold breezy day and hold the back of your hand up to the gaps around doors, windows and light fittings.

If you can feel cold air coming in then you can be sure that warm air (for which you're paying) is escaping somewhere.

Also check your letterbox, loft hatches, cat flaps to see if these need extra draught proofing.

You can find many draughts this way but of course there may be other gaps where warm air is escaping and you won't feel these with your hand in the same way-so you need to be a bit of a detective!

Doors and windows are the most common source of draughts, along with letter-boxes and keyholes. Front and back doors are normally a priority.

Don't forget to check for draughts coming between the wall and the window frame and on older windows check for draughts between the glass and the frame where the putty may have fallen out or shrunk.

Double glazing

If you are considering some form of secondary glazing then you may first wish to tackle only the more obvious draughts around windows with draught proofing strips. Secondary glazing removes draughts but has the added advantage of reducing heat loss through conduction and stopping the fall of cold air from window surfaces while providing extra sound insulation.

Curtains

Venetian blinds or louvred shutters might look neat but unless your windows are double glazed it would be far better to stick to curtains. Heavy curtains that reach to the floor will trap air and reduce draughts significantly. They can also look attractive. The use of a curtain behind the front door is also effective.

Pay Back and Grants

Draught proofing a whole house might cost £75-£90 (depending on the size of the house). If done yourself this measure will have a typical pay back of 3-4 years.

There are subsidies and grants to help pay for insulation and draught proofing. These depend upon your circumstances and existing insulation levels.

Products used in Draught Busting workshops

- Easy to fit materials used for most doors, windows and loft hatches from a company called GTi
- Products are used widely by contractors and are not adversely affected by paint or staining

Product features

- The deflection seal enables ease of operation by reducing closing forces
- The seal performance is not affected if painted over
- The product has a minimum 10 year life time

Product specification

- Supplied in 2.05 metre lengths
- Carrier is rigid high impact pvc-u with pre-punched holes at 100/150mm centres
- 20/25mm nails

Product benefits

- Resists dirt and grime
- Excellent memory-returns to original shape after compression
- Reaches out-to cope with seasonal gap size changes

Tools needed

- Hammer
- Philips screw driver
- Scissors
- Tape measure
- Junior hacksaw and/or pliers
- Pieces of stiff thick cardboard (approx 20cm x 20cm) to protect windows when hammering (BeGreen can supply)
- Nail punch
- Pliers
- Mitre block for 45 degree cuts
- Fine sandpaper to sand edges

Sash Windows-SBS strip

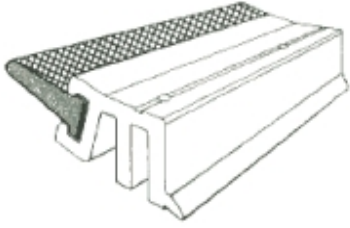

SBS strip- For Windows and Internal Doors

- Use around internal doors and windows, including sash and casement windows
- They can also be used around many loft hatches
- Easy to fit and look neat and unobtrusive
- Apply around the bottom and inside of a sash window
- Where possible apply the strips around the top sash from the outside of the window
- The strips are nailed around the window frame so it's easy to open and close the window
- Measure and cut strip for bottom of sash first and put into place, then measure sides and cut, and fit.
- If there is no access or no frame outside to attach the draught proof strip to the upper sash, try using an SBS strip attached to the inside top of sash



With window open



With window closed-forms seal

Sash meeting rails/ French doors-FS strip



FS strip-Meeting rails on sash windows, centre rails on French doors

- These cover the horizontal gap where the two sashes meet in the middle of the window
- These can be also used on French doors where the two doors meet as shown below
- If the FS strip cannot cover the gap because the two sashes do not meet on the same level then try using a self-adhesive P-strip or Zero gap strip stuck on the back of the meeting rail of the bottom of the sash
- This will help to prevent rattling and unwanted draughts blowing through the centre of the window



Outside doors -21B strip

changes
U.V. light stable

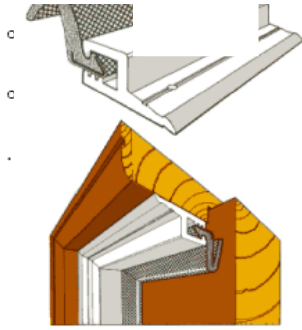
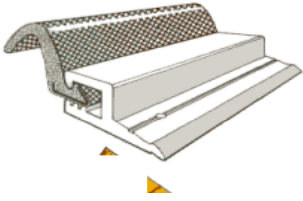

21 L/ 21B strip

- Use for External doors but can also be used internally
- The strips are applied in the same fashion as SBS strips but have more expansion capability and can cover larger gaps often needed for external doors
- Fix in place with door shut and fully locked
- Apply the strips to the top of the door frame first and then the vertical sides
- Ensure nominal compression of the seal is 3mm, and that there is a visual movement of the seal when the door is opened and closed
- You may wish to mitre the strips in the corners at a 45 degree angle
- These strips can be used to cover slightly larger gaps
- Their design makes them easier to compress so are less likely to make doors difficult to close
- These strips have more expansion capability-useful as the gaps around the outside doors tend to expand and contract more
- They can be used to cover slightly larger gaps (also on sash windows)



Outside doors -21B strip

changes
U.V. light stable

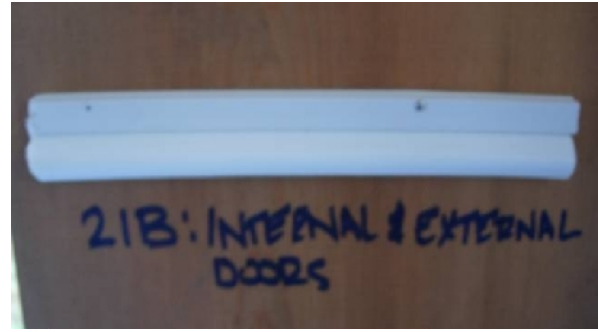
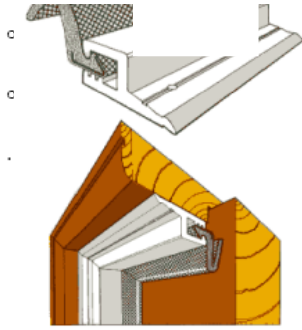
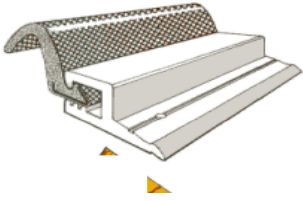

21 L/ 21B strip

- Use for External doors but can also be used internally
- The strips are applied in the same fashion as SBS strips but have more expansion capability and can cover larger gaps often needed for external doors
- Fix in place with door shut and fully locked
- Apply the strips to the top of the door frame first and then the vertical sides
- Ensure nominal compression of the seal is 3mm, and that there is a visual movement of the seal when the door is opened and closed
- You may wish to mitre the strips in the corners at a 45 degree angle
- These strips can be used to cover slightly larger gaps
- Their design makes them easier to compress so are less likely to make doors difficult to close
- These strips have more expansion capability-useful as the gaps around the outside doors tend to expand and contract more
- They can be used to cover slightly larger gaps (also on sash windows)



Installation Instructions

1. Cut with garden pruners (anvil blades give the best cut) or a junior hacksaw.
2. Cut each strip generously to start-maybe 1 cm too long and check carefully before trimming to exact size required.
3. Cut each strip and fit it and **then** cut the next one and so on.
4. Use the supplied 20/25mm stainless nails which are rustproof and have small heads.
5. Use all the pre-formed nail holes but at the end of the strips, depending on how you have cut them, you may need to insert a nail into the strip. This should be done approximately 2cm from the end to minimize any risk of splitting and into the same small groove where the pre-drilled holes are positioned.
6. Don't drive the nails all the way in at first-just half way-this will allow fine adjustment of pressure and position later.
7. The plastic flexible trim should push up against the closed window or door with gentle pressure to seal any gap but not so hard that they prevent the window closing or cause too much friction on the sliding sash.
8. With each strip in place the nails can be driven home and their angle altered slightly during hammering to increase or decrease this pressure to ensure contact with the window/door.
9. Fully drive home nails perpendicular to surface but do not over pressurise (or this may drive the nail through the PVC carrier).



LETTERBOX BRUSH

- Includes 4 screws
- Advice: position first before attaching and check that letters/papers can be posted easily and that the flap won't stick in brushes.

STRAIGHT DOOR BRUSH- CAN BE USED ON CARPETED FLOORS

- Contents: 2 Straight CLIPS - L & R 5 screws
- Instructions: Cut plastic carrier from the end without a screw hole to fit the door width. Cut the brush strip to length & crimp end with pliers.
- Use clip as a template to mark and drill a hole at the cut end to match the other end. Fix strip & brush to door with clips/screws.



Additional Draught Proofing Products

Magnaglaze Secondary Glazing System

The Magnaglaze *magnetic* system is an attractive self-adhesive secondary glazing system which attaches to the perimeter of the 2mm acrylic sheet and then to the window frame. The glazing can be removed easily by pulling the magnetic strip, attached to the acrylic, away from the metal strip attached to the window. To replace, simply align the strips and the magnetism pulls the sheet into place.

Is it suitable for my window?

The surround of the window needs to be flat and at least 15mm wide.

The only other limit to the magnetic system is that it will only hold up to about 20 square feet of 2mm acrylic. Larger areas will need additional clips or the use of 3mm acrylic. If the window frame is suitable it may be possible to stabilize the acrylic with a magnetic strip in the middle of the window.

Advantages

Magnaglaze not only cuts out drafts but also provides some double glazing heat saving and increases sound insulation. Simple to fit – but measure the window frame carefully. It can be easily removed and stored as required.

Disadvantages

Care is required when cleaning or when storing to prevent the acrylic getting scratched.

Do I still need to add draught strips to the sash window?

If the sash window is very draughty then it is advisable to reduce the draughts with Q-LON draught stripping as well as using Magnaglaze secondary glazing.

DOUBLE GLAZING FILM

- An economical alternative to double glazing.
- Easy to fit. You only need scissors, a sharp knife and a hairdryer.
- Can be found in Homebase. A 6 square meter pack is about £8.00 (07/2010).

How to Fill Floorboard Gaps with Draughtex Floorboard Insulation



DraughtEx Floorboard Filler

DraughtEx is a proven floorboard gap filler, designed to eliminate the cold draughts and improve the comfort and energy efficiency of your home.

Easy to install, DraughtEx requires no adhesives and compliments the overall finish of your floorboards. The specially formulated colour "Shadow" has been designed to mimic the natural shadows created between floorboards and is almost invisible to the naked eye.

Its flexible properties allow DraughtEx to be applied to a wide range of gaps which will be completely sealed. It can be stretched to fit narrower gaps. The filler can also be used to seal gaps between floorboards and skirting boards. DraughtEx can be ordered with an applicator and comes in 3 sizes, small for gaps of 3mm or less, medium for gaps of 2 - 7mm and large for gaps of 6-11mm.

We have samples in the BeGreen shop or you buy a sample box for £4.50 from Draughtex.

Energy Savings

Based on the results of research carried out by The Energy Saving Trust, it is estimated that filling floorboard gaps can save a household up to £20.00-£40.00/room/year on energy bills and reduce its CO2 contribution by around 110kg.

www.draughtex.co.uk
Help and Advice - Freephone 0800 088 7311

Reflective Radiator Panels

What size are the panels?

The panels are approximately 600mm wide by 520 mm high

Does the radiator have to be removed?

In almost every case the panel can easily be fitted with the radiator in place.



Will the panel be visible?

Not necessarily. The panels can easily be fitted out of the line of sight.

Do the panels only fit certain sizes of radiator?

No, the panels can be easily cut and overlapped to fit any size of radiator.

How easy is to fit the panel?

Easy to fit!

A simple operation without the need to remove the radiators. The panels are easily cut to size, and fitted to the wall behind the radiators using best quality heat resistant double-sided tape for fixing. The only tools needed are scissors and a bamboo cane or wooden spoon handle to reach the awkward corners. Use small strips of double-sided good quality sticky tape.

How does it work?

A lot of energy from radiators is wasted heating the walls behind them rather than heating the air in the room. The reflective, insulating panels change this, forcing more of the heat energy available into the room space and returning unused heat back into the radiator to reduce boiler burn times. The radiator panel causes the naturally rising hot air behind the radiator to spin, creating a series of vortices which rise at increasingly higher speeds, ultimately spinning the warm air far into the room.

How do you save money?

Reducing the primary heat loss from the radiator (through the wall) makes your heating system more efficient; allowing your boiler to burn less fuel to achieve the same room space heating. Simply put, your heating bill is reduced because you need less heat to warm the room to comfortable levels.

MEASURING YOUR DOORS AND WINDOWS

The strips we are using are difficult to find in shops. At the end of the workshop you will be able to buy the strips you need. You will be offered some strips by Camden Council (£50 worth for hosts / £20 worth for participants). The strips need to be installed on the frame of the door or window where the door or window closes.

Inside sash window



Outside sash window



— SBS strip

— FS strip

width

height

width

height

— 21L/21B strip



Record your measurements

(with examples. Print several sheets if necessary)

- Measure your windows and doors and record your measurements in the table.
- Convert these into lengths of strips: $2 \times \text{height} + \text{width}$.
- Convert these lengths into amounts of strips. Bear in mind that each strip is 2.05 meters long.
- You will have leftovers. For example, for window 1 you will have 1.15 m SBS strip and 0.95 m FS strip left for other windows.
- **This is always for 1 sash. Do not take the top/outside sash in consideration if you cannot access it.**

Item	Width	Height	SBS strip		FS strip		21L strip	
			length	quantity	length	quantity	length	quantity
/	/	/	length	quantity	length	quantity	length	quantity
Window 1	110 cm	90 cm	290 cm	2	110 cm	1	/	/
Window								
Window								
Window								
Window								
Window								
Window								
Window								
Door	90 cm	220 cm	/	/	/	/	530 cm	3
Door								
French door	114 cm	200 cm	/	/	200 cm	1	514 cm	3
French door								
TOTALS	/	/	/		/		/	